

Float Monitor

Centeron Wireless Tank Monitoring System

Centeron monitors accurately measure tank fluid level and transmit information to Centeron controllers via robust wireless data links. Centeron Float Monitors provide a cost effective means to remotely monitor small to medium sized tanks that contain a variety of fluids.

- Completely wireless
- Good for general purpose applications
- Typical fluids monitored include fuels, motor oils, lubricants, and water
- Easy to install
- Visual level indication at tank
- No calibration required
- Low maintenance
- Eliminates costly electrical wiring

Specifications:

- Measurement range: 8 feet
- Accuracy: +/- 5%
- Temperature range: -40C to + 80C
- UL50 Type 3 environmentally sealed enclosure
- 5-year battery life with 4 hour transmit interval
- Low battery indication
- Radio range: 1 mile line of sight, 500 feet obstructed
- Radio complies with FCC Part 15
- ETL/cETL listed: Intrinsically safe for use in Class I, Division 1, Group D hazardous locations

The Centeron System

We start with an easy to install monitor. It's wireless, so no special know-how or tools are needed. It's powerful, too. Our DSSS radio technology is far superior to the narrow bandwidth radios found in other wireless systems. That means you receive your data even in the harshest environments.



The monitor sends the tank level data to the controller. The

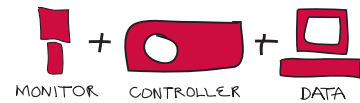

controller collects the data then sends it to the Centeron Data Center. From there, you can retrieve your info anytime, wherever you are.

Just think about what that information can mean to your business. An up-to-date, accurate account of tank level allows you to deliver your product when it needs to be delivered. Centeron puts you in control so you can manage your business better.

Call 1-865-981-3118 and speak directly to a Robertshaw applications engineer.

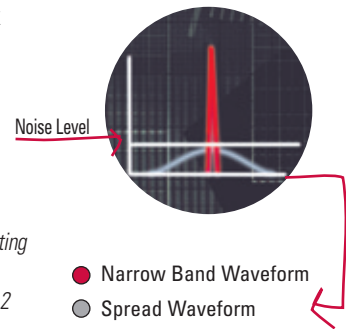

Exceptional DSSS radio technology is superior to narrow band systems, resulting in more reliable communications. So advanced, it's already the recipient of 12 patents, with additional pending.

Centeron®

The World's No. 1 Wireless Tank Monitoring System

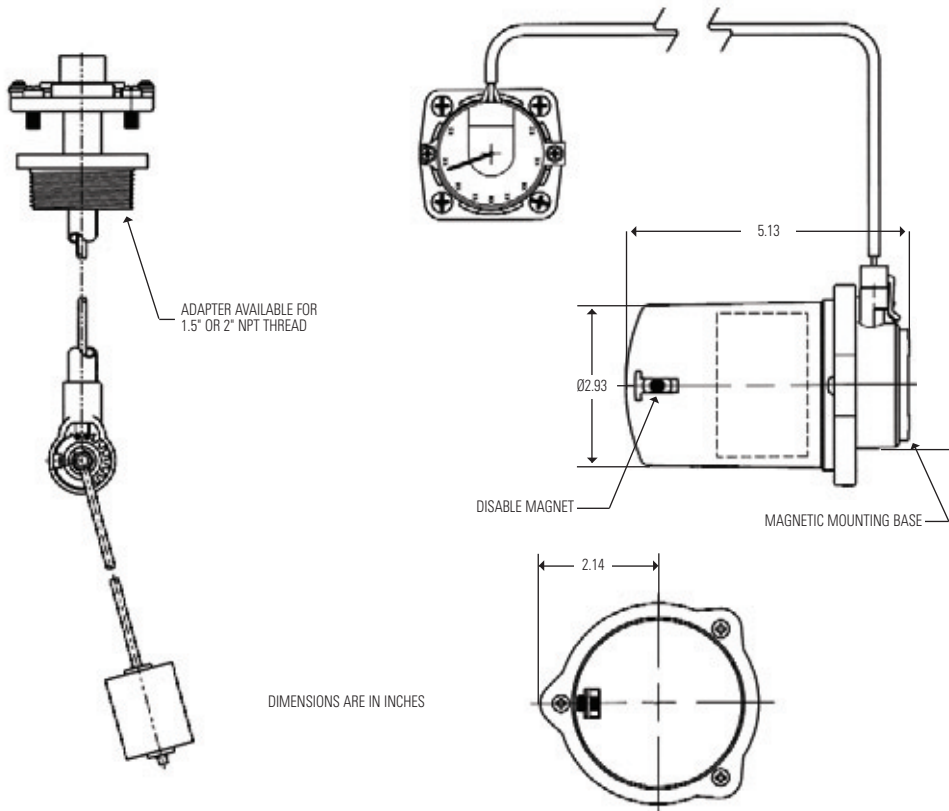

DIMENSIONS ARE IN INCHES

Float Monitor													
	0	6	0	60 Minute transmit interval									
	1	2	0	120 Minute transmit interval									
	2	4	0	240 Minute transmit interval									
	↓			A	2 ft. Cable length								
				B	5 ft. Cable length								
				C	10 ft. Cable length								
					0	3	6	36" Tank height					
					0	3	8	38" Tank height					
					0	4	4	44" Tank height					
					0	4	8	48" Tank height					
					0	6	0	60" Tank height					
					0	6	4	64" Tank height					
					0	7	6	76" Tank height					
				0	9	6	96" Tank height						
							A	1 1/2" NPT mounting adapter					
							B	2" NPT mounting adapter					
							↓						
G	M	<input type="checkbox"/>	<input type="checkbox"/>	<input type="checkbox"/>	E	<input type="checkbox"/>	<input type="checkbox"/>	<input type="checkbox"/>	<input type="checkbox"/>	F	9	P	F

ETL/cETL Marked Intrinsically Safe apparatus for use in Class I, Division 1, Group D hazardous locations, conforming to ANSI/UL 913 and CAN/CSA C22.2 No. 157.

FCC Part 15 Registered: NU9TX0669-0100

This device is manufactured by Robertshaw Controls Company, in Maryville, TN USA under the following US Patents: 4,977,577; 5,067,136; 5,119,396; 5,265,120; 5,408,217; 4,581,606; Patents pending in the US and other countries.

Robertshaw
Industrial Products

U.S.A. – Robertshaw Industrial Products
1602 Mustang Drive, Maryville, Tennessee 37801
Tel Sales: 800-237-7429 Technical Support: 865-981-3118
www.robertshawindustrial.com • www.centeron.net

Centeron[®]
Take it to a new level.